



TAMLITE LIGHTING

660 NW Peacock Blvd. Port St. Lucie, FL 34986
 tel: (772) 878-4944 or on the web at www.tamliteusa.com

SPECIFICATION & FEATURES

ORDERING INFORMATION

CATALOG#	WEIGHT	EPA RATING	FINISH
LLP200SO16CW	13 LBS.	0.4	DARK BRONZE

WARRANTY:

Guaranteed for one year against mechanical defects in manufacturing

*** SPECIFICATIONS SUBJECT TO CHANGE WITHOUT NOTICE***

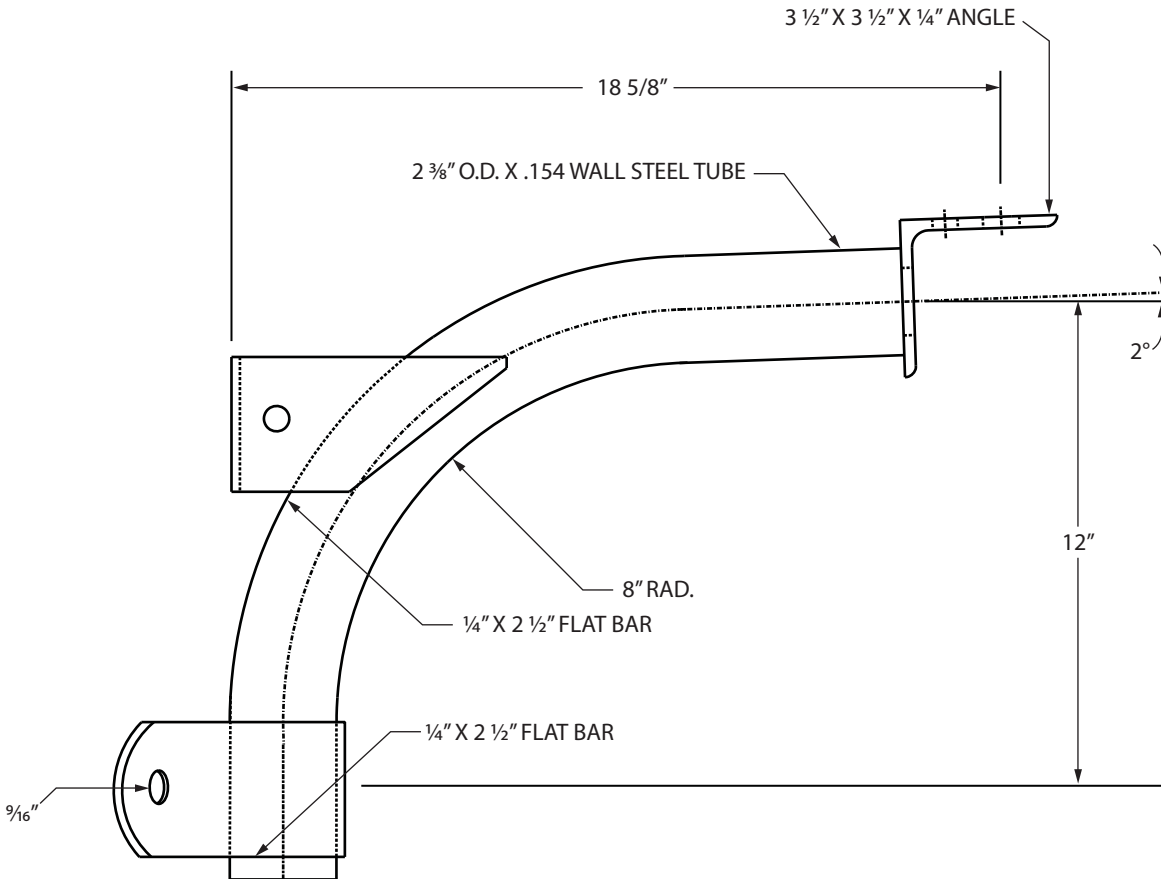

Catalog Number
Notes
Job/Title

LLP200SO16CW

Cross Arm Bracket

