

MODEL :		TYPE
PROJECT :		
PREPARED BY :	DATE :	

SERIES SPECIFICATIONS

EXR SERIES

The EXR series recessed aluminum edge-lit LED exit signs offers a sleek high end modern look with long lamp life, energy efficiency and uniform illumination.



LINE DRAWING

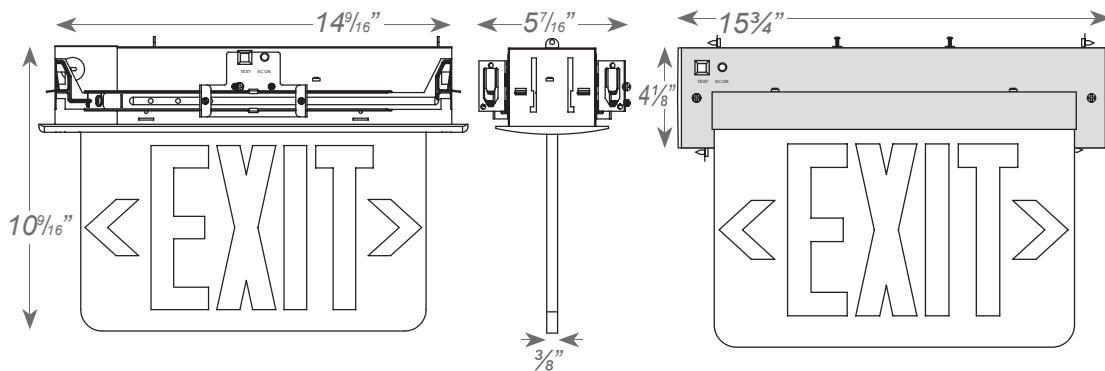

CONSTRUCTION

Housing
Premium grade, extruded aluminum housing

Transfer switch
Internal solid-state transfer switch automatically connects the internal battery to lamp heads

Chevrons
Easy snap-out chevron directional indicators.

Illumination
Ultra bright, long life Red or Green LED

Charger
Fully automatic solid-state, two rate charger initiates battery charging to recharge a discharged battery in 24 hours

Panel
UV-stabilized ultra clear acrylic edgelit panel. Double face utilizes factory installed silver or white mylar background panel

MODEL :		TYPE
PROJECT :		
PREPARED BY :	DATE :	

ELECTRICAL SPECIFICATIONS

Battery Type 4.8V Rechargeable NiCad	Emergency Illumination Minimum 90 Minutes	Battery Recharge Time 24 Hours
Low Voltage Disconnect Prevents battery from deep discharge	LED Indicator Charge rate/power "ON" and push to test switch	Battery Discharge Time 1.5 Hours
Operating Voltage 120/277	Frequency 60Hz	Operating Temp 0°C ~ 50°C

AMPERAGE/WATTAGE

CATALOG NUMBER	INPUT WATTS (W)		INPUT AMPS (A)	
	120V	277V	120V	277V
EXR	3.6	4.0	0.030	0.020
EXR-SD/DC	3.6	4.0	0.030	0.020

MOUNTING SPECIFICATIONS

Compatible with drywall or drop ceiling mount installations	Bar hangers included
---	----------------------

OPTIONS

SD Self-diagnostic feature performs monthly, biannual, and annual tests to ensure reliable operation and meet electrical and life safety codes	DC Dual circuit option on the AC-only unit enables it to be connected to two different (one acting as a back-up to the other) supplies at the same time
USA Substantial transformation assembly in the U.S. complies with "Assembled in the USA" under the Buy American Act	CW Signs available with requested "special" wording



MODEL :		TYPE
PROJECT :		
PREPARED BY :	DATE :	

CERTIFICATIONS/WARRANTY

Listing
UL Listed

Compliance
Meets UL924, cULus, NFPA 101 Life Safety Code, NEC, OSHA, Local and State Codes.

Location Rating:
Suitable for damp locations

Warranty
Guaranteed for five years from the purchase date of the product, against mechanical defects in manufacturing. Batteries are pro-rated for two years.

ORDERING INFORMATION

Part Number: EXR1RAEM

SERIES	NO. OF FACES	LETTER COLOR	HOUSING COLOR	FINISH	OPERATION	OPTIONS
EXR	[1] : Single Face	[G] : Green	[A] : Anodized Aluminum	[BLANK] : Clear (Single Face Only)	[BLANK] : A/C Only	[BLANK] : No Option
	[2] : Double Face	[R] : Red	[B] : Black	[B] : Black	[EM] : Battery Backup	[CW] : Custom Wording
			[W] : White	[M] : Mirrored		[DC] : Dual Circuit
				[W] : White		[SD] : Self Diagnostics
						[USA] : Assembled in the USA

