

MODEL :	TYPE
PROJECT :	
PREPARED BY :	DATE :

SERIES SPECIFICATIONS

The SLR-1 is a micro adjustable LED emergency light that utilizes fully adjustable LED heads, long life and environmentally friendly Ni-Cad battery in an easy to install fixture design.



LINE DRAWING

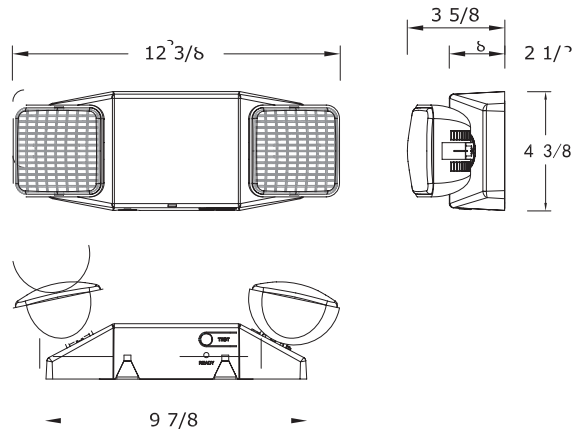

CONSTRUCTION

Housing

Injection-molded, high-impact, UV-stabilized, UL94 V-0 thermoplastic construction in white or black finish.

Transfer switch

Internal solid-state transfer switch automatically connects the internal battery to LED lamp heads

LED Lamp Heads

Two long lasting, efficient, ultra bright ED lamp heads with polycarbonate lens.

BATTERY SPECIFICATIONS

Battery Type

Rechargeable Ni-Cad

Emergency Illumination

Minimum 90 Minutes

Battery Recharge Time

24 Hours.

Low Voltage Disconnect

Prevents battery from deep discharge

LED Indicator

Charge rate/power "ON" and push to test switch

Battery Charger

Two rate, fully automatic solid-state

MODEL :		TYPE
PROJECT :		
PREPARED BY :	DATE :	

ELECTRICAL SPECIFICATIONS CONT.

Operating Voltage

120/277

Operating Temp.

10° - 40°C

Wattage

2W

Lumens

90 Lm

MOUNTING SPECIFICATIONS

Backplate

Snaps into place making internal electrical connections

Surface Mount

“Easy Connect” backplate which fits most standard junction boxes.

Conduit Mount

Mounts using knockouts on the backplate or on top of housing

Suitable for wall or ceiling mount

Options

SD:

Self-diagnostic test feature continually diagnoses unit's performance and tests system to ensure reliable operation and to meet electrical and life safety codes

RC

Optional Remote-Capable version offers up to an additional 2.3W for 90 minutes

CERTIFICATIONS/WARRANTY

Listing

UL Listed

Safety Certifications

UL924, NFPA 101 Life Safety Code, NEC, OSHA, Local and State Codes.

Location Rating:

Suitable for damp locations

Warranty

Guaranteed for five years from the purchase date of the product, against mechanical defects in manufacturing. Batteries are pro-rated for two years.

MODEL :	TYPE	
PROJECT :		
PREPARED BY :	DATE :	

ORDERING INFORMATION

Sample Part Number: SLR-1

SLR-1		
SERIES	HOUSING COLOR	OPTION
SLR-1	[BLANK] : White	[BLANK] : No Option
	[B] : Black	[SD] : Self-Diagnostic
		[RC] : Remote Capable