

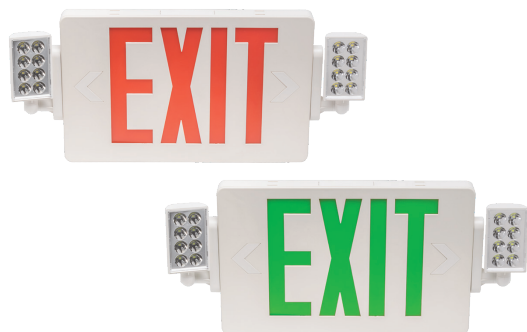

CONTRACTOR:	
PROJECT:	DATE:
PREPARED BY:	MODEL#: TXPCL

SERIES SPECIFICATIONS



TXPCL Series

Ultra Thin High Lumen Combo Exit Emergency LED Light

The TXPCL series thermoplastic LED exit sign and emergency lighting combination unit offers long lamp life, energy efficiency and uniform illumination from LED heads



FEATURES AND SPECIFICATIONS

Construction

5VA flame retardant , high impact resistant thermoplastic in white finish.

Installation

Mounting canopy included for top and end mounting.

Electrical

Dual 120/277 voltage ,LED battery indicator (green=normal, red=check battery)

Battery Recharge Time

24 Hours

Battery Type

3.6v rechargeable NiCad

Battery Discharge Time

90 mins

Warranty

5-year limited warranty.

LINE DRAWINGS

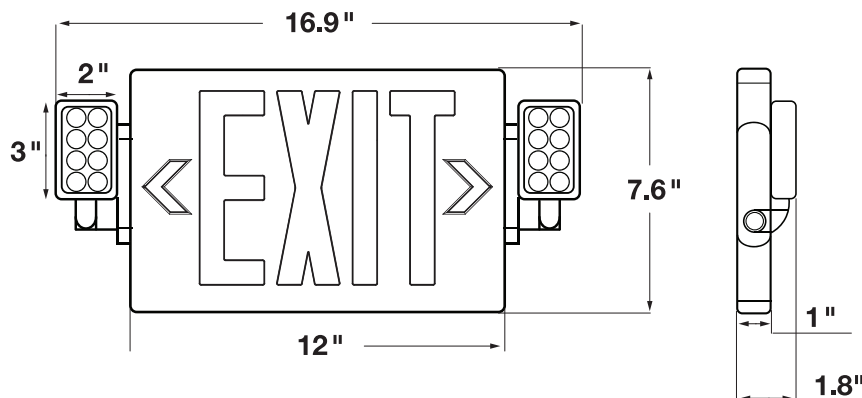



CONTRACTOR:	
PROJECT:	DATE:
PREPARED BY:	MODEL#: TXPCL

ORDERING INFORMATION

EXAMPLE: TXPCL3GWEM

SERIES	NO. OF FACES	LETTER COLOR	HOUSING COLOR	BATTERY (ALWAYS INCLUDES EM=EMERGENCY)
TXPCL	[3]: Universal Single/ Double	[R]: Red	[W]: White	[EM]: Battery Backup
		[G]: Green		