



PROJECT:	
LOCATION:	
MODEL#:	TYPE:
CLIENT:	QTY:
PREPARED BY:	DATE:

## EXE1RAEM

### SERIES SPECIFICATIONS

The EXE series extruded aluminum edge-lit LED exit signs offers a sleek high end modern look with long lamp life, energy efficiency and uniform illumination.



### ELECTRICAL SPECIFICATIONS

**Rated Input Voltage:** 120VAC / 277VAC

### EMERGENCY SPECIFICATIONS

**Battery Recharge Time:** 24hr  
**Battery Type:** 2.4V Rechargeable Ni-Cad

**Emergency Runtime:** 90Minutes

### CERTIFICATIONS

**Safety Certifications:** UL Listed

### ENVIRONMENTAL SPECIFICATIONS

**UL Location Rating:** Damp Location

### PHYSICAL SPECIFICATIONS

**Finish Color:** Aluminum  
**Housing Material:** Aluminum

**Installation Method:** Top mount, back mount, end mount

PROJECT:	
LOCATION:	
MODEL#:	TYPE:
CLIENT:	QTY:
PREPARED BY:	DATE:

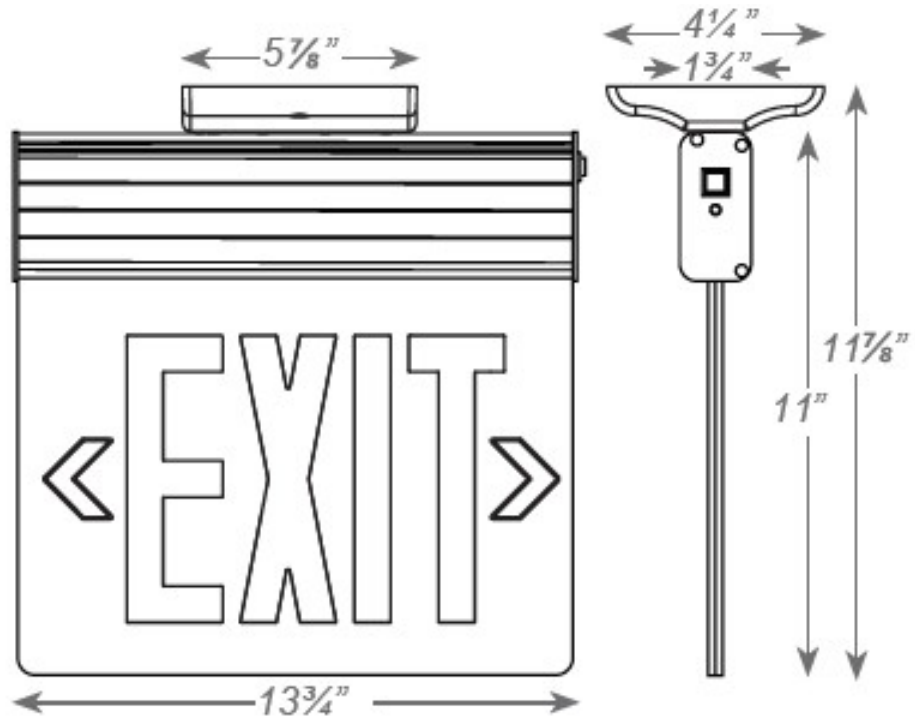

## WARRANTY INFORMATION

**Warranty:** 5 Years



PROJECT:	
LOCATION:	
MODEL#:	TYPE:
CLIENT:	QTY:
PREPARED BY:	DATE:

SERIES	NO. OF FACES	LETTER COLOR	HOUSING COLOR	FINISH	OPERATION	OPTIONS
EXE	[1] : Single Face	[G] : Green	[A] : Anodized Aluminum	[BLANK] : Clear	[BLANK] : A/C Only	[BLANK] : No Option
	[2] : Double Face	[R] : Red	[B] : Black	[B] : Black	[EM] : Battery Backup	[CW] : Custom Wording
			[W] : White	[M] : Mirror		[DC] : Dual Circuit
				[W] : White		[SD] : Self Diagnostics
						[USA] : Assembled in the USA

## SHIPPING SPECIFICATIONS

### Case

**Length:** 13.75 in.

**QTY:** 1

**Weight:** 4.5lbs

**Width:** 11.5 in.

### Master Case

**Height:** 9 in.

**Length:** 14.25 in.