



PROJECT:	
LOCATION:	
MODEL#:	TYPE:
CLIENT:	QTY:
PREPARED BY:	DATE:

CH8-OS1-12

SERIES SPECIFICATIONS

Extended trim for CH8 Series.
Trim extender comes packaged with elongated clips.



PHYSICAL SPECIFICATIONS

Housing Material: Polycarbonate



PROJECT:	
LOCATION:	
MODEL#:	TYPE:
CLIENT:	QTY:
PREPARED BY:	DATE:

CH8-OS1-12

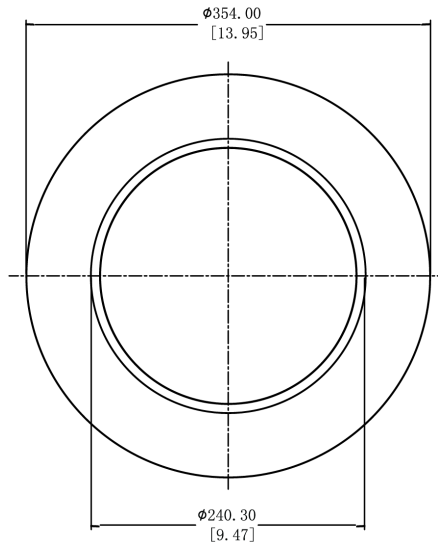

WARRANTY INFORMATION

Warranty: 1 Year



PROJECT:	
LOCATION:	
MODEL#:	TYPE:
CLIENT:	QTY:
PREPARED BY:	DATE:

SAMPLE PART #: CH8-OS1-12

SERIES	TYPE	SIZE
CH8	[-OS1] : Oversized Ring	[-12] : 8-12"

SHIPPING SPECIFICATIONS

Case

Length: 14 in.
QTY: 1

Weight: 1lbs

Master Case

Height: 14.5 in.
Length: 14.5 in.