



PROJECT:	
LOCATION:	
MODEL#:	TYPE:
CLIENT:	QTY:
PREPARED BY:	DATE:

LS-PATH-LA1-BR

SERIES SPECIFICATIONS

Designed for long-term outdoor performance, the LS Series landscape path light offers a classic look with brass construction for durability. Compatible with standard 12-volt lamps making it simple to update effects or change lamps without replacing the fixture. Perfect for illuminating pathways, gardens, and entrances with stylish accent lighting.



LUMINAIRE SPECIFICATIONS

Luminaire Type: Path light

LAMP SPECIFICATIONS

Base Type: Bi-pin (G4)
Lamp Type: LED

ELECTRICAL SPECIFICATIONS

Ballast Type: Low Voltage Transformer
Dimming: Dimmable
Rated Input Voltage: 12VAC

Rated Input Voltage Range: 11-16VAC
Wattage: 20W

CERTIFICATIONS

Safety Certifications: cULus Listed

ENVIRONMENTAL SPECIFICATIONS

IP Rating: IP65
Temperature Rating Range: -20-40°C

UL Location Rating: Wet Location

PHYSICAL SPECIFICATIONS

Conductor Material: Copper
Conductor Size: 18AWG
Connection: 4' wire leads
Finish Color: Brass
Finish Type: No Additional Finish
Housing Material: Brass

Lens Material: Polycarbonate
Mounting: Ground stake
Thread: 1/2 Inch
Weight: 2.1lbs



PROJECT:	
LOCATION:	
MODEL#:	TYPE:
CLIENT:	QTY:
PREPARED BY:	DATE:

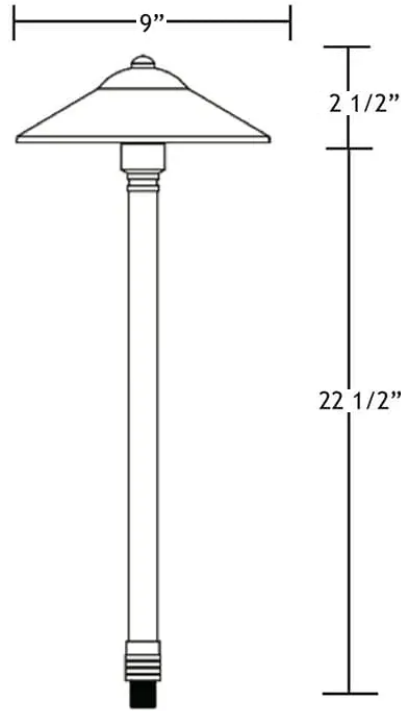

WARRANTY INFORMATION

Warranty: 5 Years

NOTES

10" Ground stake included

G4 12V lamp not included



PROJECT:	
LOCATION:	
MODEL#:	TYPE:
CLIENT:	QTY:
PREPARED BY:	DATE:

EXAMPLE: LS-PATH-LA1-BR

SERIES	TYPE	STYLE	FINISH
LS	[-PATH]: Landscape Path Light	[-LA1]: Large Architectural Style 1 G4 Lamp 12-Volt	[-BR]: Brass

**NOTE: Lamp not included*

SHIPPING SPECIFICATIONS

Package

Height: 4in.
Length: 22in.
QTY: 1

QTY UOM: ea
Weight: 3.5lbs
Width: 10in.